



Sinepower has been developing and manufacturing 400Hz solid state Frequency Converters for more than a decade now.

Our policy, has always been, to offer the best designed products that are environmentally friendly, simple to use, easy to maintain and exceptionally well manufactured thus meeting our clients requirements as well as complying with all standards and legislation.

Sinepower's GPU units were designed with Power factor correction to guarantee a perfect sinusoidal input current from 25% to 150% load and a low THDi (<2%).

Sinepower ensures high quality, efficient and secure electrical power supplies.



## INPUT

- State of the art semiconductor technology (IGBT) Rectifier
- Power Factor Correction (PF=1)
- 95% efficiency
- 4 Quadrant Operation (better response of the system and safer operation for NBPT)
- Low input harmonics (<1.5% THDi), to comply with the strictest regulations @ any load.



## OUTPUT

- Voltage compensation (Load Dependent or via Remote Feedback – Real PLUG &PLAY. Connect GPU to aircraft and voltage compensation is done automatically, no user adjustment required or additional accessories)
- 4 Quadrant Operation (better response of the system and safer operation for NBPT)
- Vector control Inverter for better response and higher efficiency.



## NORMS AND STANDARDS

- AVIATION**
- ISO 6858 - Aircraft ground support electric supplies
  - SAE ARP 5015 - Ground equipment 400 Hz ground power performance requirement

- MILITAR**
- MIL-STD-704 - Aircraft electric power characteristics

- EMC**
- EN61000-6-4 - Electromagnetic compatibility - Generic emission standard
  - EN61000-6-2 - Generic immunity standard

- SAFETY**
- IEC 60529 - Degrees of protection provided by enclosures (IP Code)
  - IEC 62477-1 - Safety requirements for power electronic converter systems and equipment

- ENVIRONMENTAL**
- Dry heat test (steady state) IEC 60068-2-2:2007 subclause 5.3
  - Damp heat test IEC 60068-2-78:2012 subclause 6
  - Vibration test IEC 60068-2-6:2007 subclause 6
  - Salt mist test IEC 60068-2-52:1996 subclause 6
  - Dust and sand test Test Lc1 of IEC 60068-2-68



## EFFICIENCY

- Up to 94% - 30KVA to 90kVA @ load PF=0.8 to 1.0
- 90% - < 30 kVA @ load PF=0.8 to 1.0
- Green Standby Function - losses: 20 W
- No load losses: <1%.



## TECHNOLOGY

- Enclosure Protection class up to IP55
- Enclosure with C5-M coating
- No break power transfer compatibility (NBPT)
- Over/under voltage at output
- Overload capability designed for:
  - Power stage 150% - Continuous
  - Magnetics 120% - Continuous
- Regulator Overload protections set at:
  - 120% for 600seconds
  - 150% for 60 seconds
  - 200% for 2 seconds
- Variable fan speed for internal temperature control
- Over temperature protection
- Short circuit proof by electric current limiting and shutdown
- 90% switch interlock

# SPECIFICATIONS

## INPUT

- 3 phase 400V/415V AC |  $\pm 10\%$ \*
- 50/60Hz |  $\pm 10\%$
- Input current harmonics |  $< 2\%$  @ Full Load

## OUTPUT

- 3 phase 200V AC -400Hz |  $\pm 1\%$ \*
- Overall Efficiency | 90%-95%
- Max. Crest Factor | 1.4:1

## RECTIFIER

- 4 Quadrant Operation
- AC Voltage Range | -25% +10%
- Efficiency | 95%-97%
- Input Frequency Deviation | 10%
- Overload Capacity | 120% Continuous
- Inrush Current | None
- Overall current limit | 150%

\* Other voltages and frequencies available on request  
\* Other Electronic Overload limits available on request

## INVERTER

- Static Regulation 0 - 100% load |  $\pm 1\%$
- Dynamic regulation 100% | 10%, recovering to 1% within 20ms
- Total harmonic distortion | Better than 2% (Linear Load)
- Electronic Limit Overload | 120%@600s; 150%@60s; 200%@5s\*
- Overload Capacity (IGBTs) | 150% Continuous
- Frequency stability |  $\pm 0.01\%$  Crystal Controlled
- Load power factor | 0-1
- Efficiency | 95%-98%
- Short circuit proof by electric current limiting and shutdown

## ENVIRONMENTAL CONDITIONS

- Coolant temperature (max) | Forced air up to 40°C
- Ambient temperature (min/max) | -40°C to +40°C
- Relative humidity (min/max) | 0% to 90% without condensation
- Pollution degree | 2
- OVC (Overvoltage Category) | 3
- Altitude | Up to 2000m



# TECHNICAL DRAWING

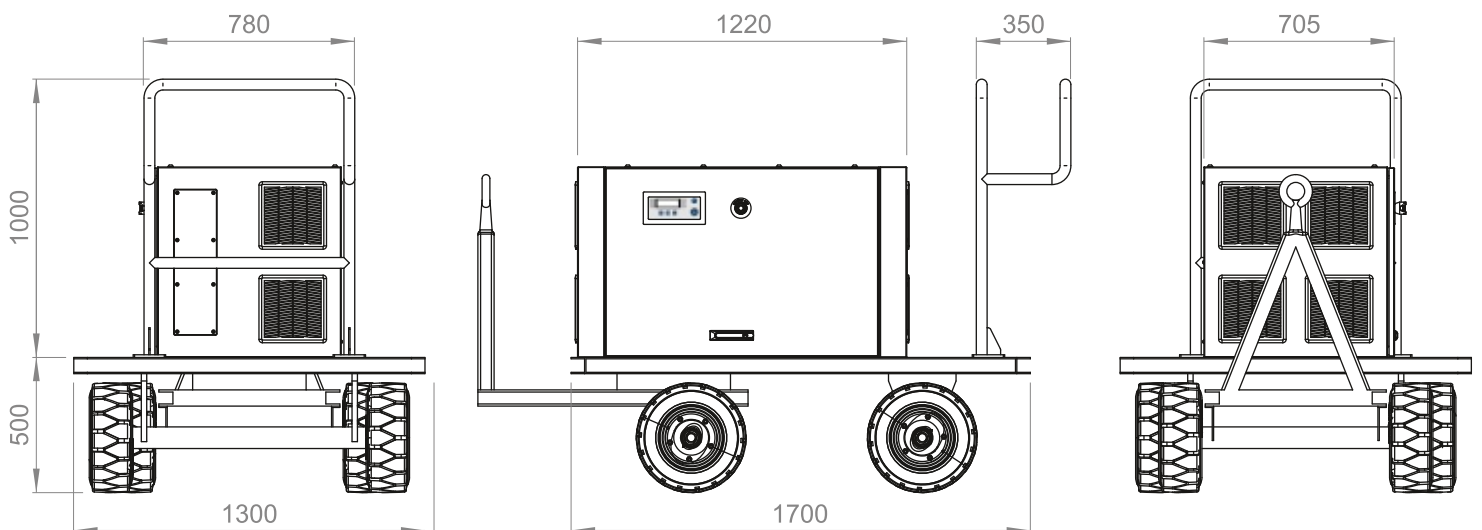

## TROLLEY SPECIFICATIONS

- Max. load | 2500Kg
- Useful length | 1700mm
- Platform height | 500mm
- Platform | Non sliding steel plate
- Max. speed | 6Km/h
- Useful width | 1300mm
- Wheels | 4.00x8 super elastic